

● Dimensions

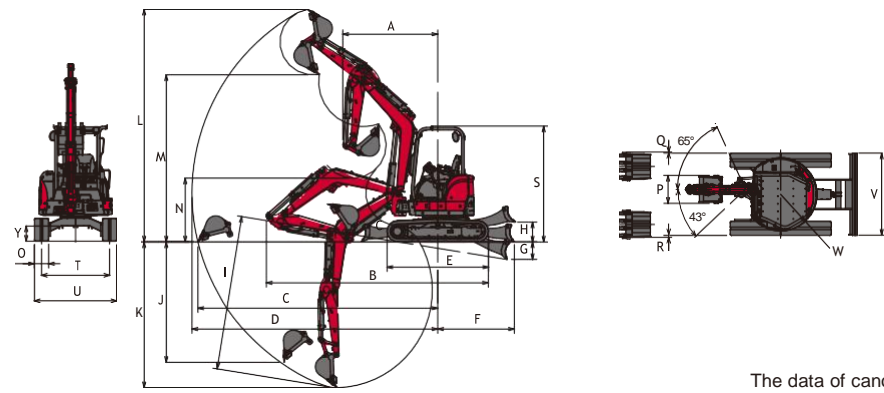

Rubber track specification
The data of canopy and cabin spec are the same.
Unit: mm (in.)

		A-cat boom swing	B	C	D	E	F	G	H	I	J	K	L	M	N	O	P	Q	R	S	T	U	V	W	Y
ViO30-6B	With quick coupler	2200 (86.6) <1980 (78.0)>	4520 (178.0)	4890 (192.5)	5020 (197.6)	2160 (85.0)	1480 (58.3)	325 (12.8)	375 (14.8)	3110 (122.4)	2160 (85.0)	2970 (116.9)	4710 (185.4)	3010 (118.5)	1110 (43.7)	300 (11.8)	540 (21.3)	85 (3.3)	135 (5.3)	2460 (96.9)	1250 (49.2)	1550 (61.0)	1550 (61.0)	775 (30.5)	320 (12.6)
	Without quick coupler	2050 (80.7) <1840 (72.4)>	4470 (176.0)	4730 (186.2)	4870 (191.7)		1630 (64.2)	370 (14.6)	425 (16.7)	3440 (135.4)	2410 (94.9)	3250 (128.0)	5110 (201.2)	3410 (134.3)	1240 (48.8)		590 (23.2)	15 (0.6)	65 (2.6)	2470 (97.2)	1440 (56.7)	1740 (68.5)	1740 (68.5)		
ViO35-6B	With quick coupler	2170 (85.4) <1950 (76.8)>	4770 (187.8)	5270 (207.5)	5390 (212.2)	2160 (85.0)	1630 (64.2)	370 (14.6)	425 (16.7)	3440 (135.4)	2410 (94.9)	3250 (128.0)	5110 (201.2)	3410 (134.3)	1240 (48.8)	300 (11.8)	590 (23.2)	15 (0.6)	65 (2.6)	2470 (97.2)	1440 (56.7)	1740 (68.5)	1740 (68.5)	775 (30.5)	320 (12.6)
	Without quick coupler	2020 (79.5) <1810 (71.3)>	4730 (186.2)	5110 (201.2)	5230 (205.9)		1630 (64.2)	370 (14.6)	425 (16.7)	3290 (129.5)	2560 (100.8)	3100 (122.0)	4960 (195.3)	3560 (140.2)	1360 (53.5)		590 (23.2)	15 (0.6)	65 (2.6)	2470 (97.2)	1440 (56.7)	1740 (68.5)	1740 (68.5)		

● Specifications

MODEL		ViO30-6B				ViO35-6B			
TYPE		With quick coupler		Without quick coupler		With quick coupler		Without quick coupler	
		Canopy	Cabin	Canopy	Cabin	Canopy	Cabin	Canopy	Cabin
WEIGHT	Operating weight	3175 (7000)	3315 (7308)	3125 (6889)	3265 (7198)	3585 (7905)	3725 (8214)	3535 (7795)	3675 (8103)
	Rubber track	3275 (7220)	3415 (7529)	3225 (7110)	3365 (7419)	3685 (8125)	3825 (8434)	3635 (8015)	3775 (8324)
ENGINE	Type	Vertical 3-cylinder water-cooled direct injection diesel engine							
	Model	3TNV88-ZSBV							
BUCKET	Rated output, gross	20.4 (27.3) / 2200							
	Capacity, standard	0.10 (3.53)				0.11 (3.88)			
PERFORMANCE	Width, standard	540 (21.3)				590 (23.2)			
	Max. digging force	23.5 (5283)	16.7 (3754)	29.9 (6722)	18.1 (4069)	25.1 (5643)	18.8 (4226)	32.1 (7216)	20.4 (4586)
SPEED	Max. digging depth <at the blade down>	2970 (116.9) <3110 (122.4)>	2820 (111.0) <2950 (116.1)>	3250 (128.0) <3440 (135.4)>	3100 (122.0) <3290 (129.5)>				
	Max. vertical wall digging depth	2160 (85.0)	2290 (90.2)	2410 (94.9)	2560 (100.8)				
GROUND PRESSURE	Max. cutting height	4710 (185.4)	4550 (179.1)	5110 (201.2)	4960 (195.3)				
	Max. dumping height	3010 (118.5)	3160 (124.4)	3410 (134.3)	3560 (140.2)				
TANK CAPACITY	Max. digging radius of the ground	4890 (192.5)	4730 (186.2)	5270 (207.5)	5110 (201.2)				
	Front min. swing radius <at swinging the boom>	2200 (86.6) <1980 (78.0)>	2050 (80.7) <1840 (72.4)>	2170 (85.4) <1950 (76.8)>	2020 (79.5) <1810 (71.3)>				
HYDRAULIC SYSTEM	Boom swing angle: left / right	43 / 65							
	Travel speed: Rubber track	4.5 (2.7) / 2.7 (1.6)							
HYDRAULIC SYSTEM	Travel speed: Steel track	9.5							
	Swing speed	10.5				9.5			
HYDRAULIC SYSTEM	With standard track	29.3 (4.25)	30.6 (4.44)	28.9 (4.19)	30.1 (4.37)	33.1 (4.80)	34.3 (4.97)	32.7 (4.74)	33.9 (4.92)
	Steel track	30.2 (4.38)	31.4 (4.55)	29.8 (4.32)	31.0 (4.50)	34.0 (4.93)	35.2 (5.11)	33.6 (4.87)	34.8 (5.05)
HYDRAULIC SYSTEM	Fuel tank	41 (10.8)							
	Hydraulic oil tank	40 (10.6)							
HYDRAULIC SYSTEM	Pump displacement	37.4 (9.9)x2 <Variable displacement pump> 20.9 (5.5)x1, 9.9 (2.6)x1 <Gear pump>				37.0 (9.8)x2 <Variable displacement pump> 26.2 (6.9)x1, 10.8 (2.9)x1 <Gear pump>			
	Relief set pressure	20.6 (2988)x2, 19.6 (2843)x1				22.1 (3205)x2, 21.1 (3060)x1			
HYDRAULIC SYSTEM	Max. P.T.O. output	58.3 (15.4)				63.2 (16.7)			

All data are subject to change without notice. Note that the standard equipment may vary. Consult your YANMAR dealer for confirmation.



YANMAR

TRUE ZERO TAIL SWING MINI EXCAVATOR

ViO30-6B/ViO35-6B

[Gross] 20.4kW <27.3HP>



YANMAR COMPACT EQUIPMENT



yanmar.com